

Features

- Gain: 60dB Typical
- Noise Figure: 2.0dB Typical
- P1dB Output Power: +22dBm Typical
- Supply Voltage: +12V @ 560mA
- 50 Ohm Matched



Typical Applications

- Wireless Infrastructure
- 5G communication
- Test and measurement Instrument

RF Microwave & VSAT
Fiber Optics

Parameter	Min.	Typ.	Max.	Min.	Typ.	Max.	Min.	Typ.	Max.	Units
Frequency Range	0.5		8	8		18	18		20	GHz
Gain	58	60	65	57	59	65	53	56	62	dB
Gain Flatness		±1.5	±2.0		±2.0	±2.5		±1.5	±2.0	dB
Gain Variation Over Temperature (-40°C~+85°C)		±1.0			±2.0			±2.5		dB
Noise Figure		2.0	3.0		2.5	3.5		3.0	4.0	dB
Input VSWR		1.6	2.0		1.6	2.0		1.6	2.0	: 1
Output VSWR		1.5	1.8		1.5	2.0		1.8	2.5	: 1
Output 1dB Compression Point (P1dB)	22	25		20	23		18	21		dBm
Saturated Output Power (Psat)		26			25			23		dBm
Output Third Order Intercept (OIP3)		35			28			25		dBm
Supply Current (I _{dd}) (V _{cc} =+12V)		560	1000		560	1000		560	1000	mA
Isolation S12		-75			-70			-70		dB

Weight	2.5 ounces(Max.)	Impedance	50ohms
Input / Output Connectors	SMA-Female	Material	Aluminum
Finish	Nickel Plated	Package Sealing	Epoxy Sealed (Standard)
			Hermetically Sealed (Option with extra charge)

Absolute Maximum Ratings

Operating Voltage	+15V
RF Input Power (RFIN)	-35dBm

Biassing Up Procedure

Step 1	Connect Ground Pin
Step 2	Connect input and output
Step 3	Connect +12V biasing

Power OFF Procedure

Step 1	Turn off +12V biasing
Step 2	Remove RF connection
Step 3	Remove Ground

Environmental Specifications

Operational Temperature	-40°C~+85°C
Storage Temperature	-50°C~+105°C
Altitude	30,000 ft. (Epoxy Sealed Controlled environment)
	60,000 ft. 1.0psi min (Hermetically Sealed Un-controlled environment) (Optional)
Vibration	25g RMS (15 degrees 2KHz) endurance, 1 hour per axis
Humidity	100% RH at 35°C, 95%RH at 40°C
Shock	20G for 11msec half sine wave, 3 axis both directions

Outline Drawing:

All Dimensions in mm (inches)

Heat Sink required during operation(Sold Separately)

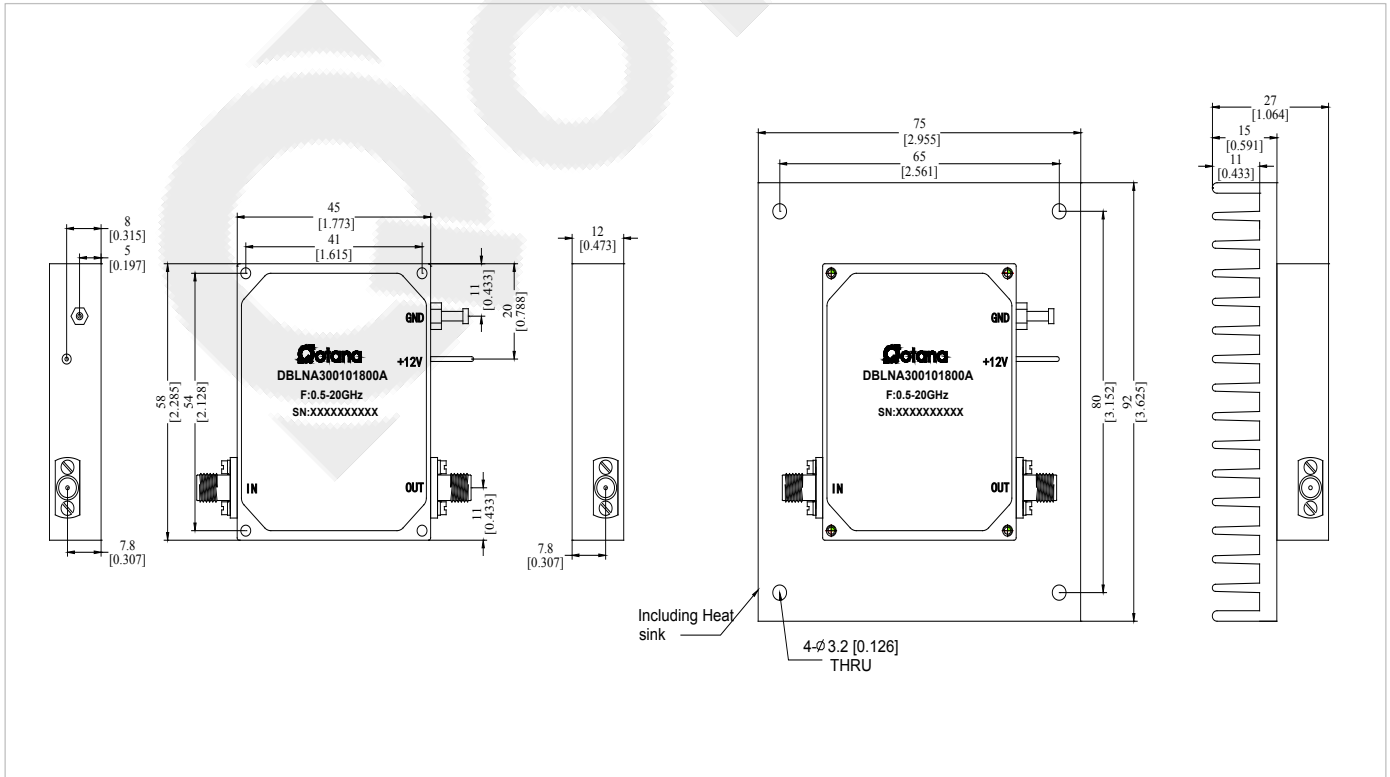

QOTANA TECHNOLOGIES

Ultra Wide Band Low Noise Amplifier 0.5GHz~20GHz

Gain@+25°C

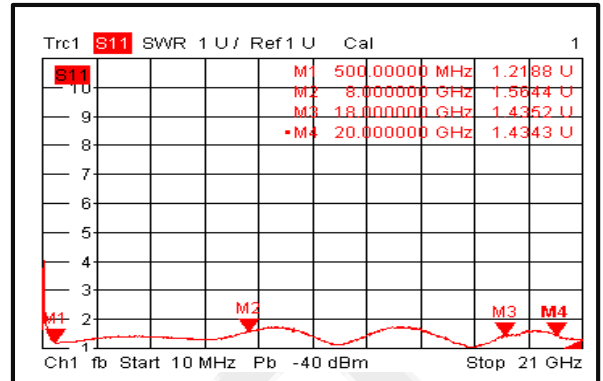
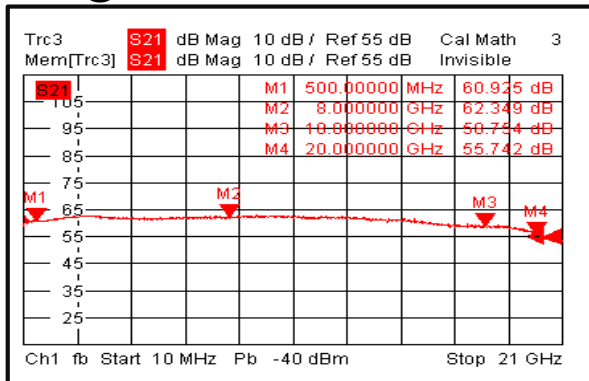

Output VSWR@+25°C

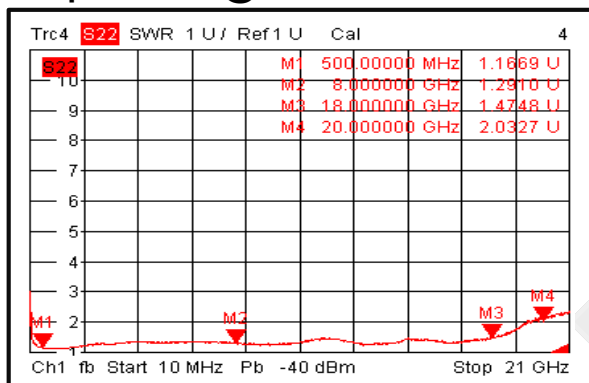

Isolation@+25°C

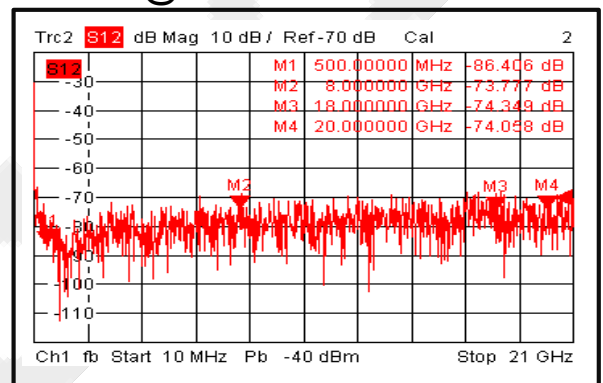

Gain@-40°C

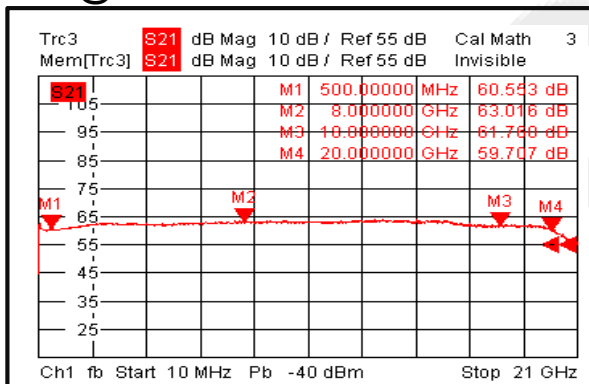

Input VSWR@-40°C

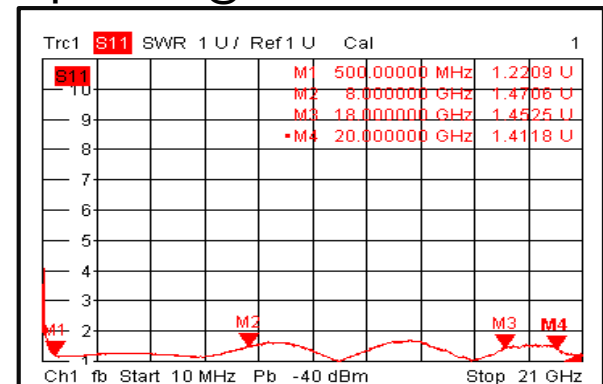

Output VSWR@-40°C

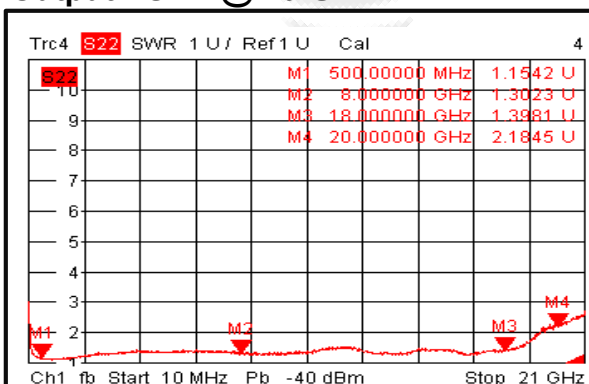

Isolation@-40°C

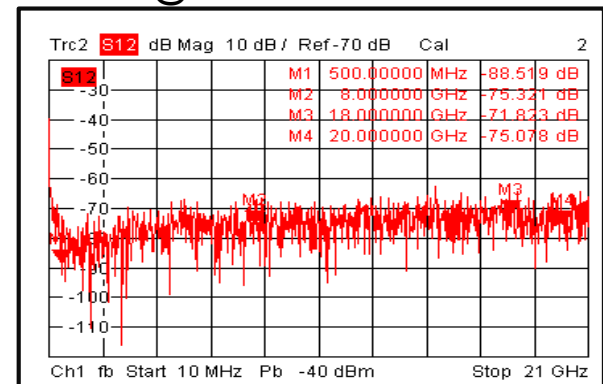

QOTANA TECHNOLOGIES
Gain@+85°C

Ultra Wide Band Low Noise Amplifier 0.5GHz~20GHz
Input VSWR@+85°C

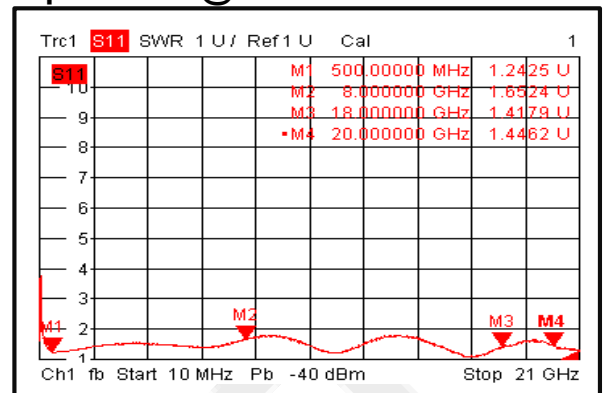
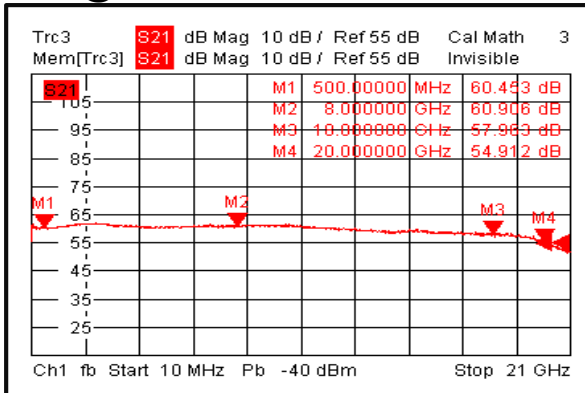

Output VSWR@+85°C

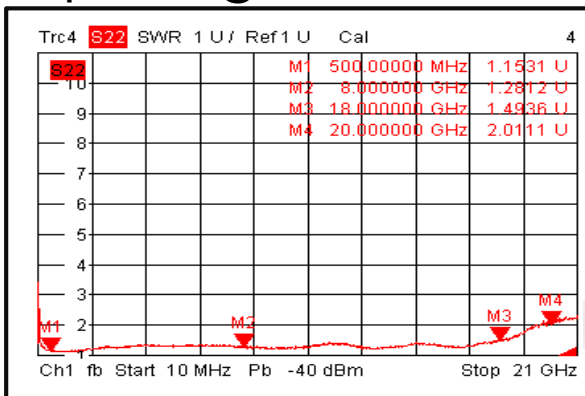

Isolation@+85°C

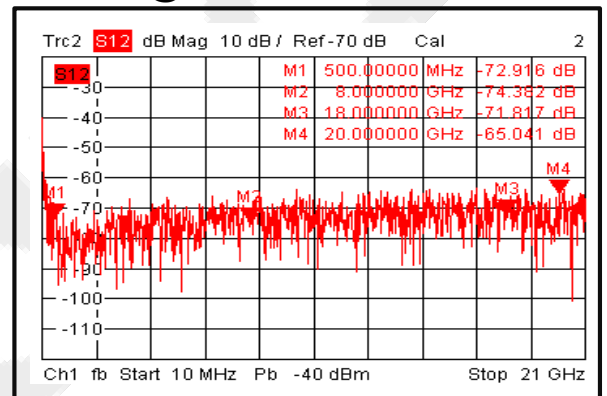

Gain vs. Output Power

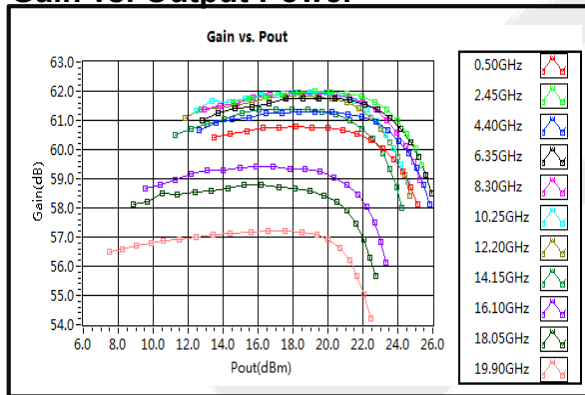

P1dB vs. Frequency

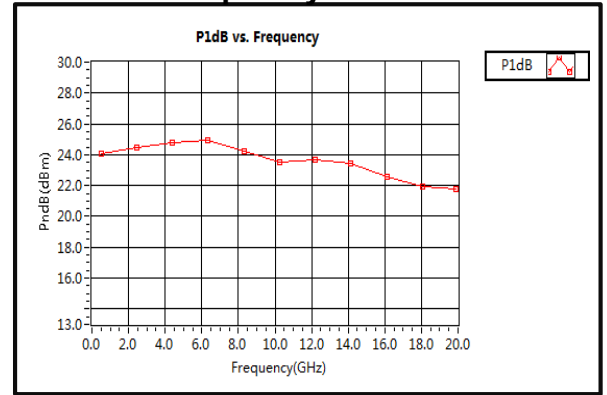

Output Third Order Intercept (OIP3)

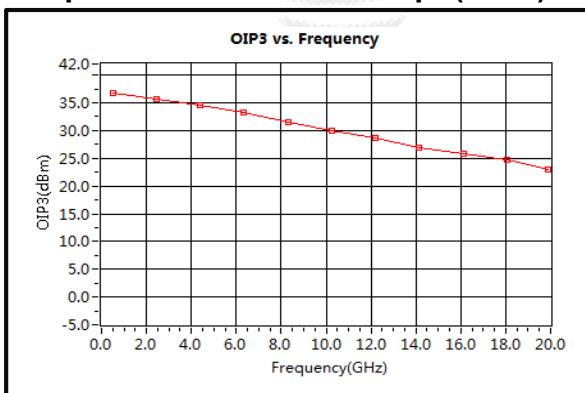

Saturation Power vs. Frequency

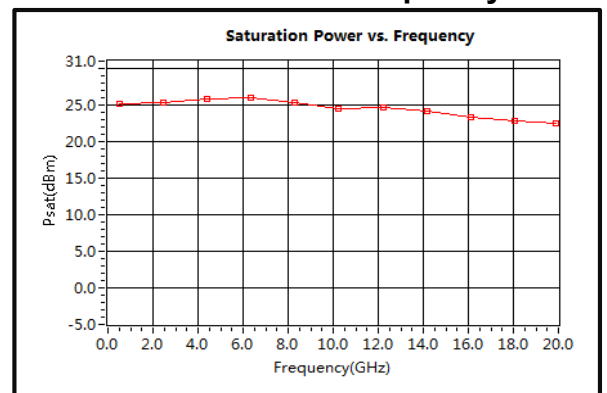

Noise Figure(500MHz-4GHz)

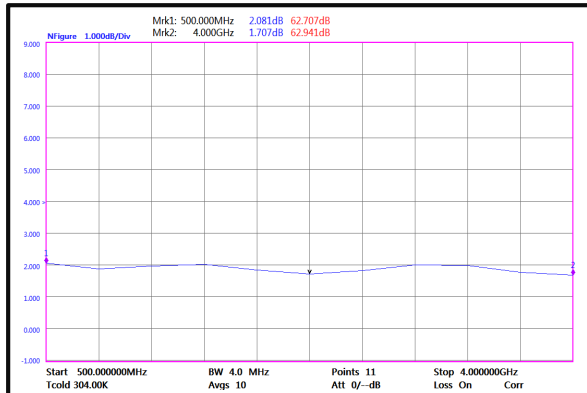

Noise Figure(4GHz-20GHz)

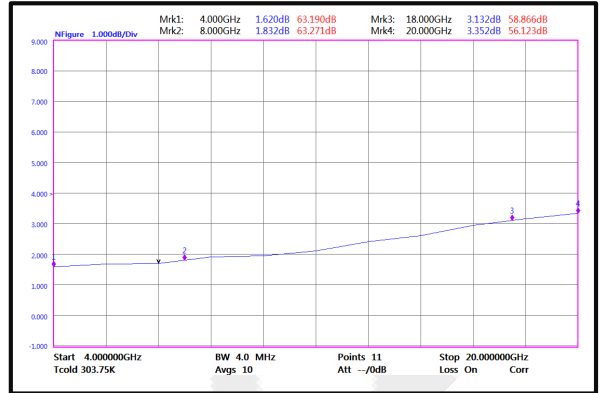

2nd Harmonic Wave Output Power

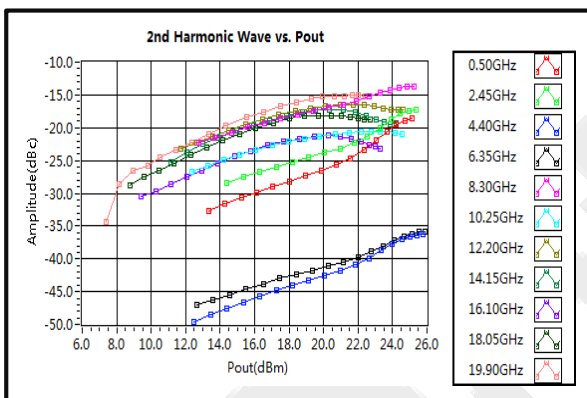

3rd Harmonic Wave Output Power

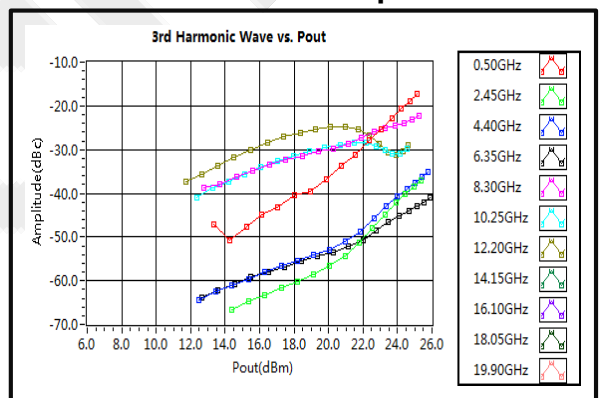

4th Harmonic Wave Output Power

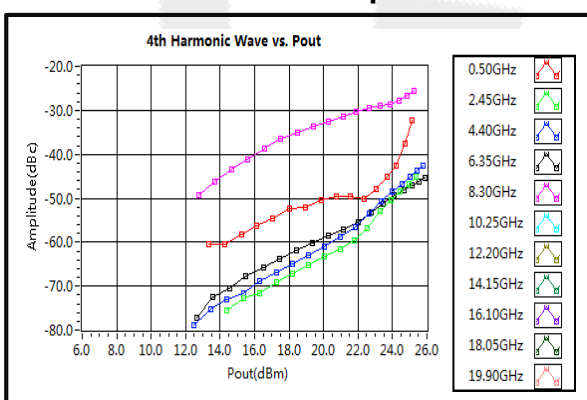

QOTANA TECHNOLOGIES and its affiliates reserve the right to make changes to the product(s) or information contained herein without notice. Visit www.qotana.com for additional data sheets and product information.